

STK seals for EBARA® pumps

Stramek offer a wide range of seals to suit Ebara® pumps, especially European models, including many standard range seals such as the STK CS3, CS3DIN and STK CS26 seals. The following are specific dimension seals designed to suit the internal dimensions of certain Ebara® pumps.

STK 198 to suit evm- and evmw- series pumps

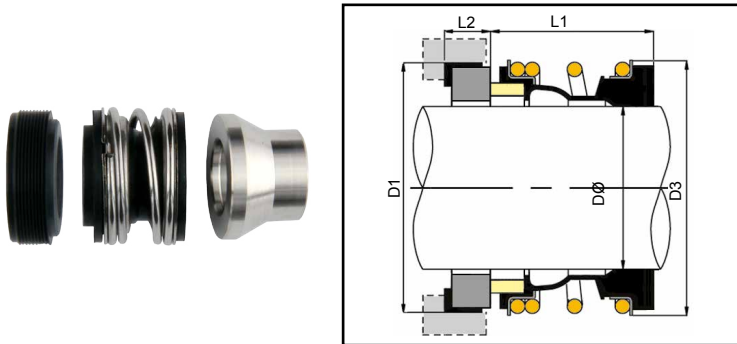

Rubber-bellow seals with boot mounted stationaries and Stainless Steel spacer-rings, to suit internal dimensions of Ebara® “EVM” and “EVMW” vertical multi-stage pumps.

SHAFT SIZE DØ	SIZE CODE	D1	D3	L1	L2
0.500	0127	23.00	24.00	15.00	8.60
16.00	0160	26.00	27.10	17.00	10.00
20.00	0200	35.00	36.00	21.50	11.50
28.00*	0280	43.00	47.00	26.50	10.00

STK 260A to suit best-, right- and dw- series pumps

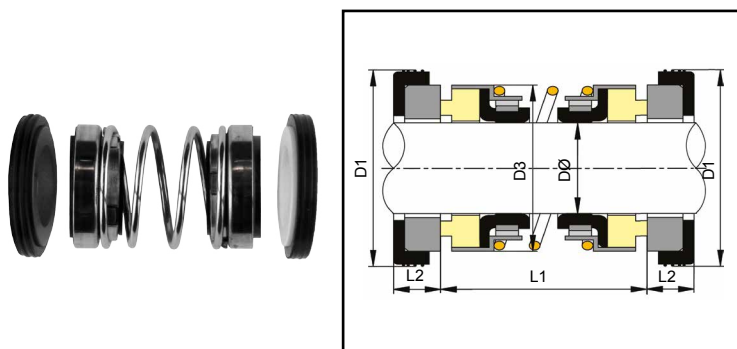

Rubber diaphragm double-ended seals with boot mounted stationaries, to suit the internal dimensions of Ebara® “Best-”, “Right-” and “DW-” series, small submersible pumps. This common seal STK is also utilised by other pump manufacturers for small portable submersible pumps.

SHAFT SIZE DØ	SIZE CODE	D1	D3	L1	L2
14.00	0140	30.00	20.00	26.00	5.00
15.00	0150	30.00	20.00	26.00	5.00
16.00	0160	30.00	20.00	26.00	5.00

seals for EUREKA® pumps

STK 277 to suit cg- series pumps

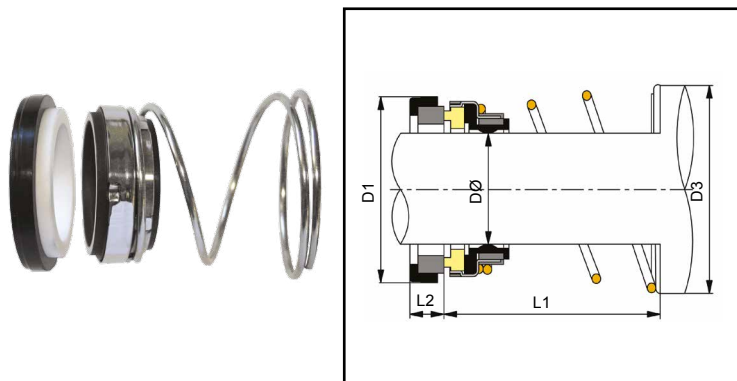

Stramek manufacture and stock a variety of standard range seals to suit various Eureka® pumps (now part of Hamworthy®, formerly Thune-Eureka®). STK 277 is an elastomer diaphragm seal, with reverse taper seal to specifically suit the “CG-” series centrifugal pumps, widely used in marine applications.

SHAFT SIZE DØ	SIZE CODE	D1	D3	L1	L2	O.E.M. REF.
29.00	0290	47.63	46.00	32.00	11.99	CGA
35.00	0350	53.98	53.00	31.50	11.99	CGB
41.00	0410	60.35	59.30	32.50	11.99	CGC
48.00	0480	66.70	66.00	38.50	11.99	CGD
54.00	0540	73.05	70.00	41.00	13.50	CGE

STK 278 to suit cac, cav and cax series pumps

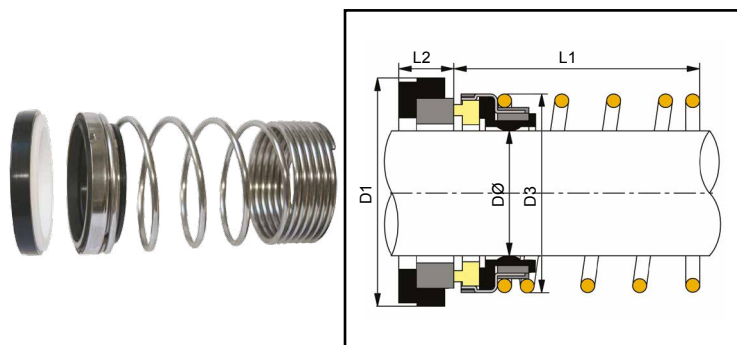

Elastomer diaphragm seals to 2.3/8” shaft size, with extended taper coil, to suit internal dimensions of Eureka® “CAC, CAV and CAX-” series centrifugal pumps, widely used in marine applications.

SHAFT SIZE DØ	SIZE CODE	D1	D3	L1	L2
2.375	0603	79.40	82.00	82.60	13.50